



Sponsored by



SENIOR PHYSICS CHALLENGE
(Year 12)

10th MARCH 2023

This question paper must not be taken out of the exam room

Name: _____

School: _____

Total Mark /50

Time Allowed: One hour

- Attempt as many questions as you can.
- Write your answers on this question paper. **Draw diagrams.**
- Marks allocated for each question are shown in brackets on the right.
- **Calculators:** Any standard calculator may be used, but calculators must not have symbolic algebra capability. If they are programmable, then they must be cleared or used in “exam mode”.
- You may use any public examination formula booklet.
- Scribbled or unclear working will not gain marks.

This paper is about problem solving and the skills needed. It is designed to be a challenge even for the top Y12 physicists in the country. If you find the questions hard, they are. Do not be put off. The only way to overcome them is to struggle through and learn from them. Good Luck.

Important Constants

Constant	Symbol	Value
Speed of light in free space	c	$3.00 \times 10^8 \text{ m s}^{-1}$
Elementary charge	e	$1.60 \times 10^{-19} \text{ C}$
Planck constant	h	$6.63 \times 10^{-34} \text{ J s}$
Mass of electron	m_e	$9.11 \times 10^{-31} \text{ kg}$
Mass of proton	m_p	$1.67 \times 10^{-27} \text{ kg}$
Acceleration of free fall at Earth's surface	g	9.81 m s^{-2}
Avogadro constant	N_A	$6.02 \times 10^{23} \text{ mol}^{-1}$
Radius of Earth	R_E	$6.37 \times 10^6 \text{ m}$
Radius of Earth's orbit	R_0	$1.496 \times 10^{11} \text{ m}$

$$T_{(\text{K})} = T_{(^{\circ}\text{C})} + 273$$

$$\text{Volume of a sphere} = \frac{4}{3}\pi r^3$$

$$\text{Surface area of a sphere} = 4\pi r^2$$

$$v^2 = u^2 + 2as$$

$$v = u + at$$

$$s = ut + \frac{1}{2}at^2$$

$$s = \frac{1}{2}(u + v)t$$

$$E = hf$$

$$R = \frac{\rho \ell}{A}$$

$$P = Fv$$

$$P = E/t$$

$$P = VI$$

$$V = IR$$

$$v = f\lambda$$

$$P = \rho gh$$

$$R = R_1 + R_2$$

$$\frac{1}{R} = \frac{1}{R_1} + \frac{1}{R_2}$$

$$PV = \text{const.}$$

$$\frac{PV}{T} = \text{const.}$$

Qus. 1-4 Circle the best answer.

1. A car tyre lasts typically 40 000 km. Estimate the number of rotations it makes during its lifetime.

- A. 10^5 B. 10^6 C. 10^7 D. 10^8 E. 10^9

[1]

2. Wine can be produced in large vats, shaped as in **Fig. 1**. The graphs below are suggested indications of the pressure as a function of depth. Which is the most suitable graph?

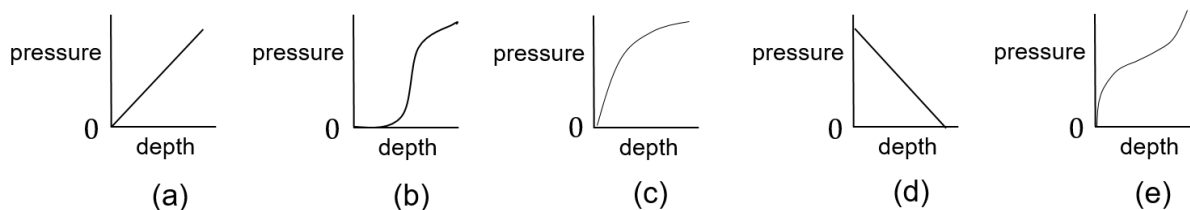

- A. (a) B. (b) C. (c) D. (d) E. (e)

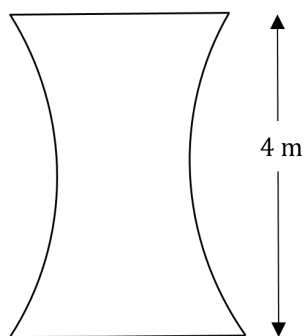

Figure 1

[1]

3. A steady sound of 165 Hz is produced by a loudspeaker at one end of a field and it is received 157 m away. By what fraction of a cycle (measured in degrees from 0 to 360°) is the received signal out of phase?

The speed of sound in air is 330 m s^{-1}

- A. 0° B. 45° C. 90° D. 135° E. 180°

[1]

4. A girl standing on a cliff throws two balls, one up and one down, at the same speed. How do the final velocities of each compare as they hit the sea?
- A. The ball thrown down has a greater velocity than the ball thrown up
- B. If the height going up is greater than the drop down to the sea, then the ball thrown up will have a greater velocity
- C. If the height up is less than the drop down, then the upwards ball will have a lower velocity
- D. The same
- E. The result depends upon the magnitude of the speed of the throw of the two balls

[1]

5. The idea of centre of mass is an important concept and is more appreciated with examples of its use.
- (a) A 34 cm long uniform straight rod lies on a smooth horizontal surface and it is seen to be spinning round whilst also moving across the surface (*translating*). At one particular moment in time it is observed that the velocities of the ends of the rod are normal to the rod and have values, 2.6 m s^{-1} and 4.2 m s^{-1} as illustrated in **Fig. 2**.

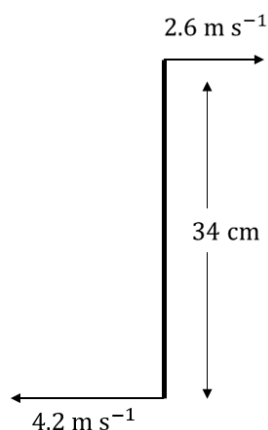

Figure 2: A uniform rod which is rotating and translating across a smooth horizontal surface.

- i. Sketch several diagrams of the rod as it would be seen sliding across the surface (i.e. across the page here).

[3]

ii. At what speed would you need to fly over the rod as an observer to see only its rotational motion?

[1]

iii. At what frequency does it rotate?

[2]

iv. If we observe the rod a quarter of a rotation later, what is the magnitude of the velocity of one of its ends?

[2]

(b) A cable of mass m hangs from two fixed points **A** and **B** and forms a smooth curve, as in **Fig. 3(a)**. In **(b)**, force F is applied to the centre of the cable in order to straighten it.

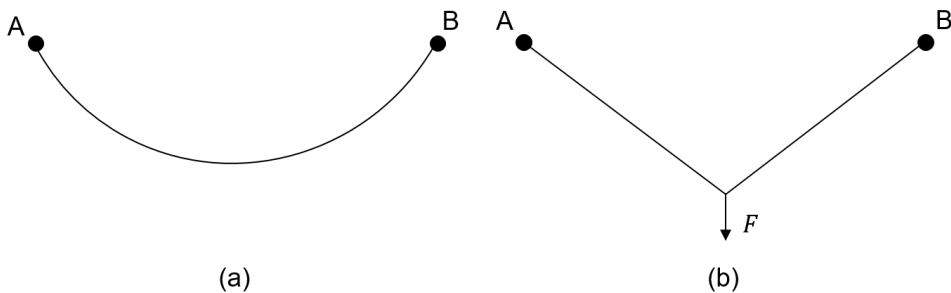

Figure 3: A massive cable suspended from two fixed points. In (a) it hangs under its own weight, in (b) a force F is added to straighten the cable.

i. On the sketch of **Fig. 3(a)**, mark on with an **(X)** the approximate location of the centre of mass.

[1]

- ii. When a force F is applied to straighten the cable, explain any change this makes to the centre of mass, and why.

[3]

6. A rod of mass m_1 is constrained to move vertically by a pair of guides, as shown in **Fig. 4**. The rod is in contact with a smooth wedge of mass m_2 and angle θ , which itself sits on a smooth horizontal surface. At time $t = 0$ the rod is released and moves downwards, whilst the wedge accelerates to the right.

- (a) The weight of the rod is constant, and the force acting on the smooth slope of the wedge is constant. What significant conclusion can be made about the type of motion of the rod and the motion of the wedge as a result?

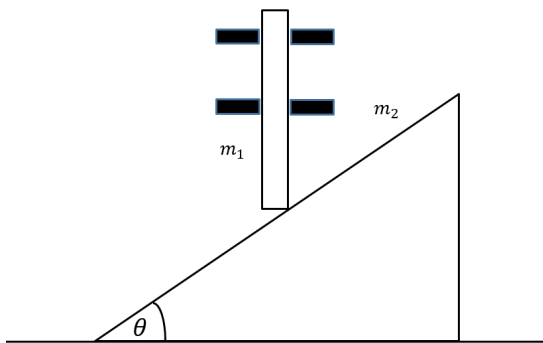

Figure 4: Rod guided vertically to slide down the smooth slope of a massive wedge.

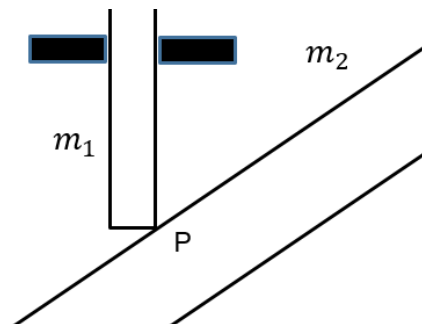

Figure 5: The motion of the wedge and rod.

[1]

- (b) As the wedge slides to the right at speed v , the rod slides down at speed u . Copy **Fig. 5** and mark on it the motion of the contact point **P** on the slope, as it moves to the right in time Δt . Similarly, add the new contact point of the end of the rod which moves downwards at speed u in time Δt . Use this, or an alternative idea, to relate u , v and the angle of the slope θ .

[2]

- (c) If the rod falls through height h and the rod and slope reach speeds u and v respectively, write down an energy equation for the system in terms of m_1, m_2, u, v, g and h .

[2]

- (d) Now obtain an expression for the speed of the wedge v in terms of m_1, m_2, g, h and θ .

[1]

- (e) If $m_1 = m_2$ and $\theta = 30^\circ$, what fraction of the GPE lost by the rod in falling is gained by the wedge?

[1]

- (f) From this, write down an expression for the speed of the rod, u . Using this and the ideas introduced earlier, write down an expression for the acceleration of the rod.

[2]

7. A bulldozer runs on a continuous track, sometimes called a caterpillar track, as shown in the image of **Fig. 6**. The driving wheel at the front has a diameter of 1.0 m and rotates once in 0.84 s. A person standing at the side of the bulldozer as it drives past sees a large piece of mud stuck to the top side of the moving track (at about 1 m above the ground).



Figure 6: The moving caterpillar track on a bulldozer.

At what speed relative to the person is the mud moving past them?

[4]

8. For many questions, drawing a diagram is the key to unlocking the ideas and unwrapping the question. A diagram should be large, should represent the scales described in the question and should be correct. It may require improving several times to get it right. In the following, you are asked to draw the diagram for this situation and calculate an angle only.

Three uniform beams **AB**, **BC** and **CD**, of the same thickness and of lengths ℓ , 2ℓ and ℓ respectively, are connected by smooth hinges at **B** and **C**, and rest on a perfectly smooth sphere of radius 2ℓ so that the middle point of **BC** and the extremities, **A** and **D** are in contact with the sphere.

Sketch a diagram of the beams and sphere in the space below, and calculate the obtuse angle between beams **AB** and **BC**.

[4]

9. (a) The terminal voltage of a dc power supply is measured as 5.00 V when it is on open circuit. A $2.00\ \Omega$ resistor is connected across the terminals and the voltage drops by 0.100 V.
- i. If the supply is treated as a simple emf and internal resistance, what would be the value of the internal resistance?

[2]

- ii. If the load resistor is reduced to $0.400\ \Omega$, what would be the terminal voltage now?

[2]

- (b) Some electronic devices are designed to take a constant current, irrespective of the voltage applied.

Such a circuit with a constant current device attached is illustrated in **Fig. 8**, in which the constant current device takes 0.40 mA.

A moving coil voltmeter with a needle moving over a scale, such as that illustrated on the right in **Fig. 7**, in fact works by taking a small sample of current and is factory calibrated to show a voltage on the scale. At full scale deflection, the meter draws a current of 1.0 mA. On the 300 V range, when connected in the circuit of **Fig. 8**, it reads 90 V.

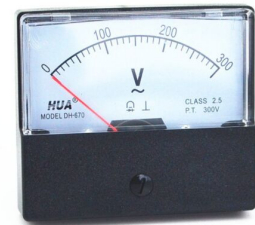

Figure 7: Moving coil voltmeter

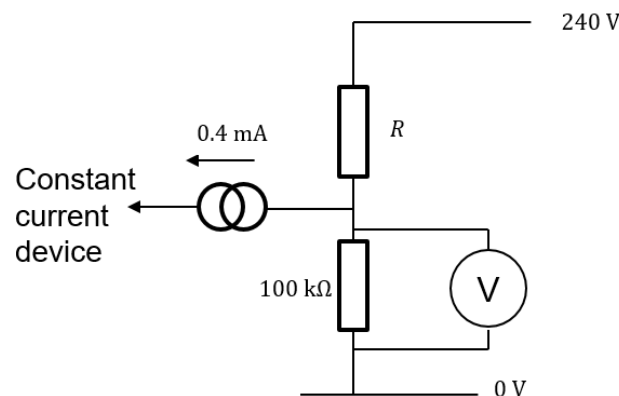

Figure 8: Constant current device connected in a circuit with and then without the moving coil voltmeter.

What is the voltage applied to the device with the voltmeter removed from the circuit?

[3]

10. A spherical shaped party balloon can be filled by blowing air into it. We observe that it is difficult to start the balloon expanding, but it becomes easier once the rubber has stretched a little. It is easier to inflate the balloon a second time. This behaviour is illustrated by the graph of **Fig. 9** and is described by the equation,

$$P_{\text{in}} - P_{\text{out}} = \frac{C}{r_0^2 r} \left[1 - \left(\frac{r_0}{r} \right)^6 \right] \quad (1)$$

where P_{in} is the pressure inside the balloon, P_{out} is the external atmospheric pressure, r_0 is the uninflated radius of the balloon, r is the radius of the balloon, and C is a constant.

- (a) What are the dimensions of C in terms of [m], [kg], and [s]?

[1]

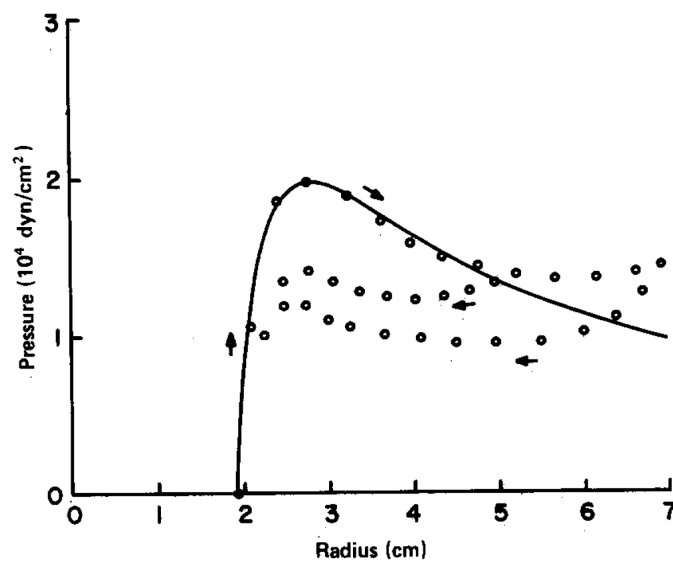

Figure 9: Pressure curves for a rubber balloon. Circles are experimental points of several inflations. The solid curve is equation 1 adjusted to pass through the pressure maximum for the initial inflation. ref. Merritt DR, F Weinhaus Am. J. Phys. 46(10), pp 976-7 Oct1978

- (b) The pressure curve for a rubber balloon is shown in **Fig. 9**. This 1978 paper by Merritt and Weinhaus uses old cgs (cm, g, s) units of pressure for $P_{\text{in}} - P_{\text{out}}$ on the vertical axis. Give an estimate from the graph of the maximum value of the pressure shown, giving your answer in pascals.

[1]

- (c) By taking two regions on the graph, estimate the work done in blowing up the balloon to a radius of 6 cm. From the equation $WD = F\Delta x$ we obtain $WD = P\Delta V$.

[2]

- (d) From equation (1) above, what is the relation between the uninflated radius r_0 and the radius at maximum pressure r_p ?

[2]

- (e) In the case of two similar balloons filled so that they are of unequal radii, and joined by an open tube, they will reach the same pressure.

- i. If the lower pressure balloon is of initially greater radius, in what configuration of radii will the two balloons finish up?

[2]

- ii. If the lower pressure balloon is now of initially lesser radius, under what condition would the balloons end up with equal radii?

[2]

END OF PAPER

The BPhO is sponsored by

